

# ELISE CANARD

## NOTE

Please confirm product contents and accessories BEFORE paint and installation. Product is non-returnable after painting.

Since glue may still be on the surface of the canard, the surface will need to be roughened before painting.

When you use double-stick tape on appropriate parts, please do so after parts have been wiped down with cotton wool and remove dust or oil.

For your safety, please make sure the canard is firmly attached before use.

## Product Contents

- Canard
- 4 U-shaped clamps with allen screws: 1A - 20mm x 2 and 1B - 40mm x 2
- Flat brackets: 2A - 180mm and 2B - 80mm x 2 (not used on US cars)
- 2 15mm spacers
- 5 M5x20 bolts
- 2 M6x25 bolts (not used on US cars)
- 2 M6x35 bolts
- 1 roll of double-stick tape

# GUT sport

## ELISE CANARD

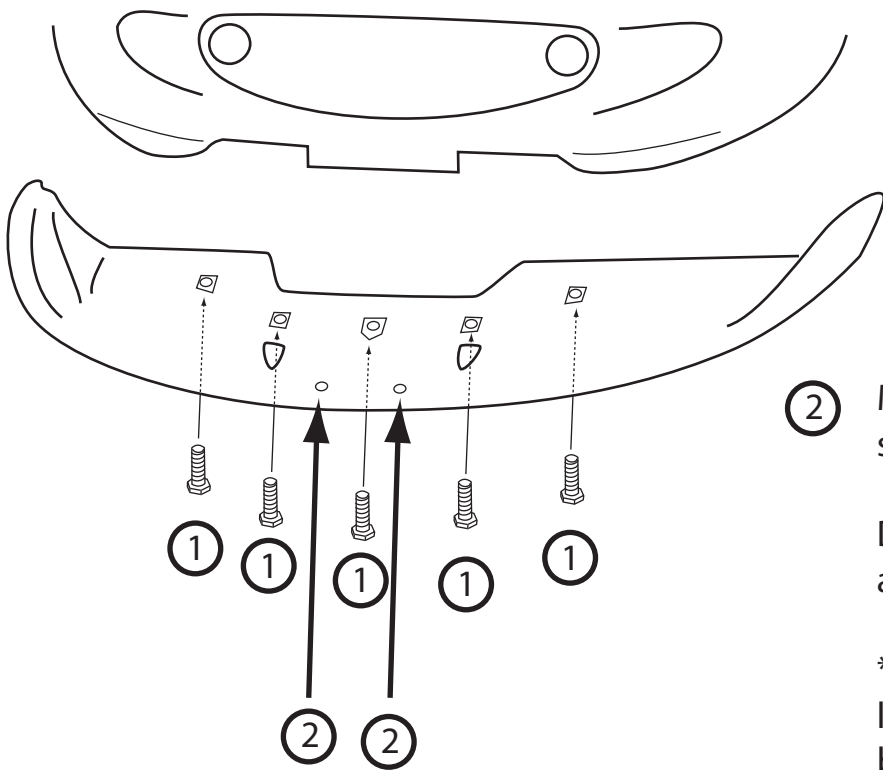

① Fix spoiler temporarily in place using supplied M5x20 bolts.

② Mark holes in locations on spoiler as shown by #2 arrows. Detach Splitter.

Drill holes in locations marked by #2 arrows\*.

\*Note: You may want to confirm drill locations by lining up bracket 2A beneath the license plate plinth.

③ Remove front grill by releasing clips along top portion of grill.

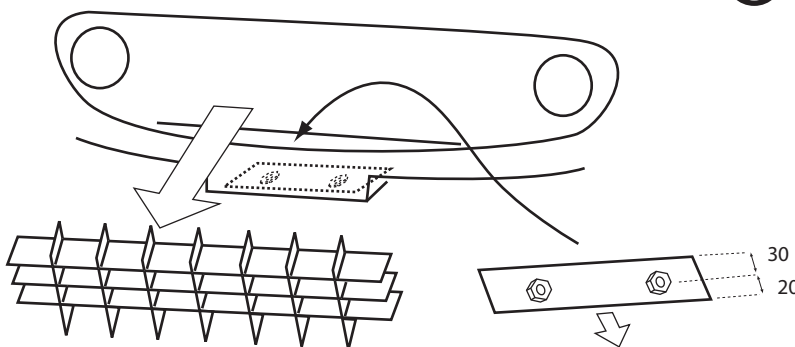

Carfully place bracket 2A at base of license plate plinth with the flat side facing downward, and shortest distance between the nut and edge towards the front of the car.

Check that the drilled holes line up with the bracket.

# GUTT

sport

## ELISE CANARD

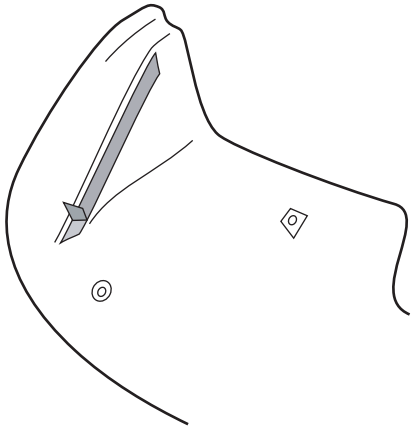

- ④ Place double-sided tape on inside of canard on area shown in diagram. Before removing sticky side towards car, confirm drilled hole alignment in front.

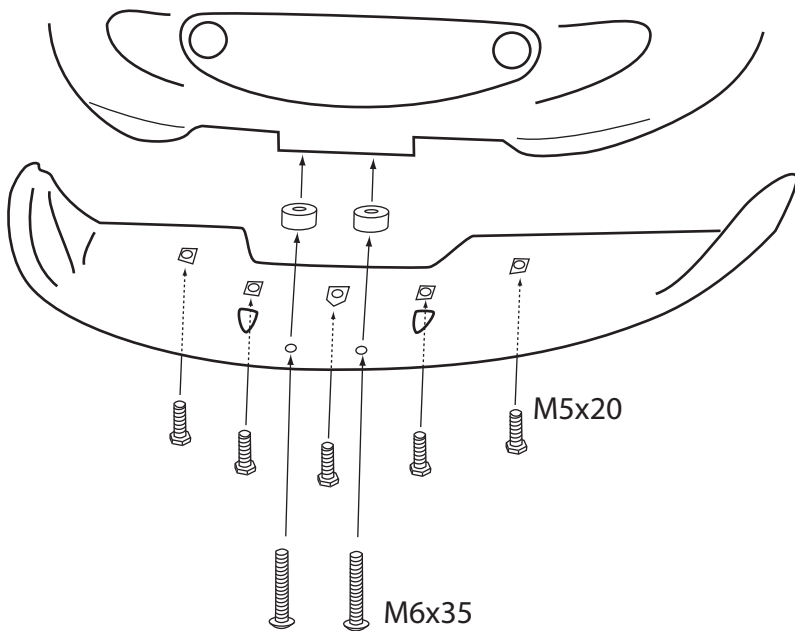

- ⑤ Refit splitter using supplied M5x20 bolts in the back and M6x35 bolts with supplied aluminum spacers in the front.

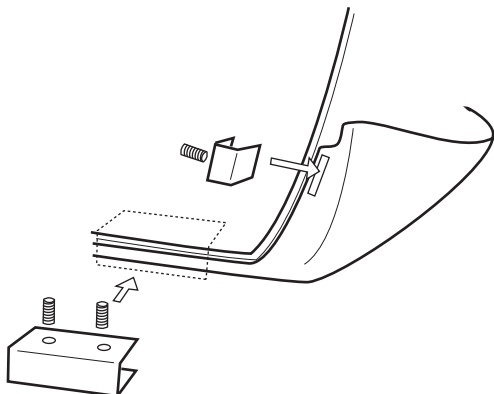

- ⑥ Place clamps 1A and 1B in locations noted in drawing. Tighten with Allen wrench.